

HYDROGEN PRODUCTION FROM ETHANOL STEAM REFORMING IN A SOLID OXIDE FUEL CELL (SOFC) - A THEORETICAL ANALYSIS OF THE SYSTEM EFFICIENCY

Aline Lima da Silva
Bianca Bairros Rabello da Silva
Cibele Melo Halmenschlager
Célia de Fraga Malfatti
Maria Madalena de Camargo Forte
Iduvirges Lourdes Müller
als14br2000@yahoo.com.br
bianca-rabello@ig.com.br
cibelemh@yahoo.com.br
malfattimc@gmail.com
mmcforte@ufrgs.br
ilmüller@ufrgs.br

Abstract. In SOFC, high operative temperature allows the direct conversion of ethanol into H₂ to take place in the electrochemical cell. Direct internal reforming of ethanol, however, can produce undesirable products that diminish system efficiency and, in the case of carbon deposition over the anode, massive forces within the electrode structure lead to its rapid breakdown. In this context, a thermodynamic analysis is fundamental to predict the product distribution as well as the conditions favorable for carbon to precipitate inside the cell. Hence, the aim of this work is to find appropriate ranges for operating conditions where carbon deposition in SOFC is not feasible. The effects of hydrogen consumption on anode components and on carbon formation are investigated. Equilibrium determinations are performed by the Gibbs energy minimization method. The effect of the type of solid electrolyte (oxygen-conducting and hydrogen-conducting) on carbon formation is also investigated. A new approach to model the direct internal steam reforming of ethanol in SOFC is presented. Theoretical SOFC (oxygen-conducting) efficiencies are accomplished in the region where carbon formation is thermodynamically impossible. The results of this work are consistent with previous results from literature.

Keywords: Ethanol energy, Direct internal reforming, SOFC, Thermodynamic simulation, Carbon deposition

1. INTRODUCTION

Among the various types of fuel cells, the solid oxide fuel cell (SOFC) has attracted considerable interest as it offers the widest potential range of applications, possibility for operation with an internal reformer, and high system efficiency (Assabumrungrat et al., 2004). Due to environmental concerns related to the reduction of atmospheric pollution and greenhouse gas emissions such as CO₂, NO_x and hydrocarbons, there have been many researches about fuel cells using hydrogen as fuel. Hydrogen gas can be produced by several routes; a promising one is the steam reforming of ethanol. This route can become an important industrial process, especially for sugarcane producing countries. Ethanol is renewable energy and presents several other advantages over other sources related to natural availability, storage and handling safety. Concerning ethanol utilization on fuel cells, the comparative study of Maggio et al. (1998) between methanol, ethanol and methane fueled molten carbonate fuel cells, revealed that ethanol exhibits better electrochemical characteristics such as (a) higher power density for every inlet fuel flow rate (b) higher electromotive force at each current density (at the same fuel flow rate and operation conditions) and (c) significantly higher electrical output. Tsiakaras and Demin (2001) showed that ethanol can also be considered as a good candidate fuel for the production of electrical power by using solid oxide fuel cells. In SOFC, high operative temperatures allow the direct conversion of ethanol into H₂ to take place in the electrochemical cell, which can improve the system performance and reduce its size. According to Jamsak et al. (2006), although two types of electrolytes are possible for the SOFC operation, an oxygen ion conducting electrolyte is more commonly used than a proton conducting electrolyte. Indeed, there are very few works related to the use of the proton conducting electrolytes. Demin and Tsiakaras (2001) presented a thermodynamic analysis of a hydrogen fed SOFC based on a proton conductor. In a more recent work, Shimada et al. (2004) investigated the high temperature proton conductor BaZr_{0.4}Ce_{0.4}In_{0.2}O_{3-α}. This work is aimed at finding suitable ranges of operating conditions where carbon formation in the SOFC with direct internal reforming (DIR) operation is not feasible. This is necessary because carbon deposition over the anode results in the growth of carbon filaments attached to anode crystallites that generate massive forces within the electrode structure leading to its rapid breakdown (Clarke et al., 1997). The calculation is more complicated than that for the conventional reformers because it is necessary to take into account the electrochemical reaction. The ranges are compared between SOFCs with oxygen-conducting (SOFC-O₂⁻) and hydrogen-conducting (SOFC-H⁺) electrolytes. In this work, an approach to calculate equilibrium compositions, considering the electrochemical reaction, is presented. Besides, calculations concerning electromotive force and efficiency were done for SOFC with an oxygen ion conducting electrolyte in order to establish the influence of the temperature and of the inlet H₂O: ethanol ratio on the theoretical SOFC-O₂⁻ efficiency.

2. METHOD

In the present study, the equilibrium compositions were calculated through the Gibbs energy minimization method. The total free energy of the system may be expressed as

$$G = \sum n_i G_i^0 + \sum n_i RT \ln y_i + \sum n_i RT \ln P \quad (1)$$

Where the 0

i G is the Gibbs energy at standard state, R is the gas constant, T is the temperature, P is pressure and y_i is the molar fraction. The problem is to find the different values of n_i (moles of specie i) which minimizes the objective function given by Eq. (1), subject to the constraints of elemental mass balance

$$\sum_{i=1}^N n_i a_{K_i} = A_K \quad K=1..M \quad (2)$$

In Eq. (2), a_{Ki} is the number of gram atoms of component K in a mole of the species i, A_K is the number of moles of component K and M, N are the total number of moles of components and species, respectively. The nonlinear programming model, comprising the objective function, Eq. (1), to be minimized, and constraints, Eq. (2), is solved using the Sequential Quadratic Programming algorithm (SQP) implemented in fmincon function of MATLAB's toolbox optimization. In previous works from literature, Mas et al. (2006) reported that there are only five species of noticeable concentration in thermodynamic equilibrium: CO, CO₂, H₂, H₂O and CH₄. For this reason, these are the only species considered in the computations throughout this work. Thermodynamic data for describing the Gibbs energy of the species were obtained from Knacke et al. (1991) and Sandler (1999). When the SOFC is operated with an internal reformer, it is necessary to take into account the electrochemical reaction. In this work, two types of solid electrolytes are analyzed in SOFC operation: oxygen-conducting and hydrogen-conducting electrolyte. The difference between both types of electrolytes is the location of the water produced. While with an oxygen-conductive electrolyte, water is produced in the anode, with the hydrogen-conducting electrolyte, water appears on the cathode. For a better understanding of the system under consideration in each case, we show a schematic SOFC-O²⁻ and SOFC-H⁺, in this work, through Fig. 1 and Fig. 2, respectively. As can be seen in Fig. 1, there are additional oxygen atoms entering into the system. The O₂ (gas) is reduced at the cathode, and the ions O²⁻ flow toward the anode and react with the hydrogen and the others species of the system under consideration. On the other hand, in Fig. 2, it can be seen that H₂ is leaving the system, due to its oxidation ($H_2 = 2H^+ + 2e^-$).

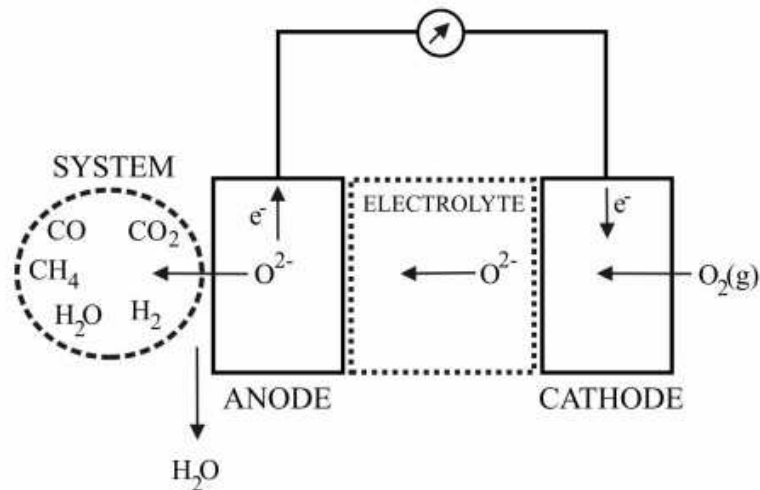

Figure 1- Schematic SOFC-O²⁻. Additional oxygen atoms are entering into the system.

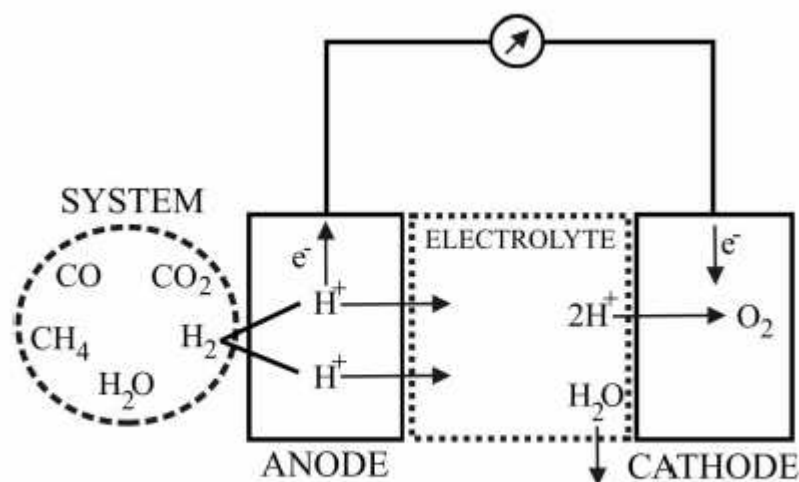

Figure 2- Schematic SOFC-H⁺. Hydrogen (H₂) is leaving the system.

In this way, the calculation of equilibrium compositions, using the Gibbs energy minimization method, must consider the following changes in Eq. (2), due to the additional oxygen atoms in the system or due to the hydrogen that is leaving the system: (a)

For oxygen-conducting electrolyte For the restriction associated to the component oxygen (K=O), Eq. (2) becomes:

$$\sum_{i=1}^N n_i a_{O_i} = A_O + n_O \quad (3)$$

Where n_O is the number of moles of oxygen that is entering in the system (additional oxygen atoms in the system). (b) For hydrogen-conducting electrolyte

For the restriction associated to the component hydrogen (K=H), Eq. (2) becomes:

$$\sum_{i=1}^N n_i a_{H_i} = A_H - n_H \quad (4)$$

Where n_H is the number of moles of hydrogen that is leaving the system. In order to find suitable ranges of inlet steam/ethanol ratio where carbon is thermodynamically unfavorable, we employ the mathematical relationship between Lagrange multipliers and carbon activity (with reference to graphite phase), deduced in our previous work (Silva et al., 2008), Eq. (5):

$$\ln a_C = \left(-\frac{G_C^0}{RT} \right) + \frac{\lambda_C}{RT} \quad (5)$$

Where C is the Lagrange multiplier associated to component carbon and a_C is the carbon activity. When $a_C > 1$, the system is in a metastable equilibrium and carbon formation is observed. The system is at equilibrium when $a_C = 1$. When $a_C < 1$, carbon formation is thermodynamically impossible.

2.1 Electromotive force (E) and efficiency

In the present work, calculations concerning SOFC-O₂- electromotive force and efficiency were done. The distribution of molar fractions of the equilibrium mixtures along the anode was calculated. It was assumed that an inlet gas into the SOFC-O₂- anode channel is an equilibrium mixture at boundary of carbonization (minimum H₂O/ethanol mole ratio, in the initial system, at which carbon formation, in the equilibrium mixture, is thermodynamically impossible). When this mixture is passing along the anode, the species are gradually oxidized electrochemically by oxygen spontaneously supplied through the solid electrolyte (additional moles of oxygen are entering into the system, as shown in Eq. (3) and Fig. 1). The electromotive force (E) of a cell is the maximum possible voltage, which drives charges around an electrical circuit in an SOFC. In practice, the actual voltage is less than this theoretical value due to activation, ohmic, and concentration losses. In this work, only the maximum possible voltage of the cell was considered, neglecting all losses. The electrode potential can be calculated using the Nernst equation. The potential can be expressed as:

$$SOFC-O^{2-} : E = \frac{RT}{2F} \left(\ln \frac{P_{O_2(c)}^{0.5} P_{H_2(a)} K}{P_{H_2O(a)}} \right) \quad (6)$$

Where "a" and "c" stand for anode and cathode, respectively. It was supposed that the SOFC cathode space is fed by air and therefore $p_{O_2(c)} = 0.209$. Where K , in Eq. (6), is the equilibrium constant associated to the reaction:

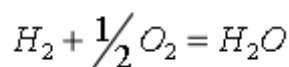

When a current is drawn from the SOFC, the maximum work produced by the SOFC can be calculated using the following equation:

$$W = q \bar{E} \quad (7)$$

Where W is the electrical work from the SOFC and q is an electrical charge passing through the electrolyte. Here, $q=12F$ and F is the Faraday constant. The average electromotive force, \bar{E} , was calculated by means of numerical integration along the SOFC length. The SOFC system efficiency is defined as the ratio of electrical work produced by the SOFC to the chemical energy of fuel spent in the SOFC system. Therefore, the maximum SOFC system efficiency was calculated by using the following equation

$$\eta = \frac{q \bar{E}}{-\Delta H^0} \quad (8)$$

Where $-\Delta H^0 = 1235$ kJ/mol and represents the lower heating value of ethanol at the standard conditions.

3 RESULTS AND DISCUSSION

3.1 Effect of the electrochemical reaction on anode components

In this study, the direct internal reforming (DIR), in which ethanol is reformed at the anode part of a fuel cell was investigated. Two types of selective electrolytes (SOFC-O₂- and SOFC-H⁺) were studied at the same conditions for the purpose of comparison. Figures 3 (a) and 3 (b) present the influence of the electrochemical reaction on anode species for the fuel cells with oxygen-conducting and hydrogen-conducting electrolyte, respectively. As shown in these figures, the consumption of hydrogen by the electrochemical reaction affects the equilibrium composition especially for the case with the oxygen-conducting electrolyte. In Fig. 3 (a) can be seen that, with increased hydrogen consumption, the carbon dioxide concentration increases, whereas the carbon monoxide decreases. The number of moles of steam at anode increases, as steam is the main product from the electrochemical reaction.

On the other hand, by using the hydrogen-conducting electrolyte, steam is generated at the cathode side. Besides, as can be seen in Fig. 3 (b), there is almost no effect on anode species (H₂O, CO and CO₂).

For both cases, the number of moles of methane was almost zero. These results, for the SOFC-H⁺ (Fig. 3 (b)), are in perfect agreement with those reported by Assabumrungrat et al. (2004). On the other hand, for the SOFC-O₂- (Fig. 3 (a)), the results are similar, but not exactly the same. This discrepancy is due to the fact that those authors employed a different approach. They performed equilibrium calculations through the stoichiometric method and assumed that only hydrogen could react electrochemically with oxygen supplied from the cathode side. In the present work, however, where equilibrium is determined by Gibbs energy minimization method and the restriction associated to the component oxygen is modified due to additional oxygen atoms that come from the cathode side, all species of the system, considered in Fig. 1, are able to react electrochemically with oxygen supplied from the cathode side. According to Tsiakaras and Demin (2001), both hydrogen and carbon monoxide are oxidized electrochemically by oxygen supplied through the solid electrolyte. In „Fuel Cell Handbook“ (2002), the following possible anodic reactions are presented:

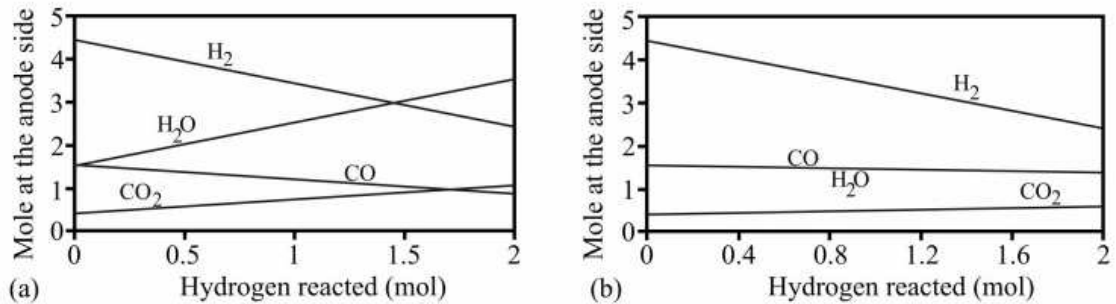

Figure 3 – Influence of electrochemical reaction of hydrogen on moles of species at the anode side, for H₂O:ethanol=3:1 and T=1173 K; (a) SOFC-O₂⁻ and (b) SOFC-H⁺.

3.2 Effect of the electrochemical reaction on carbon formation

Figure 4 (a) presents the influence of the operating temperatures on the inlet water to ethanol ratio required, for avoiding carbon formation, considering different number of moles of additional oxygen, for the case of the SOFC-O₂⁻. A higher number of moles of additional oxygen in the system results in a decrease of the boundary of carbonization for all operating temperature range. On the other hand, as can be seen in Fig. 4 (b), when a SOFC-H⁺ is employed, a higher water to ethanol ratio is necessary for avoiding carbon formation. Considering only the aspect of carbon formation inside the cell, it is possible to see that operation with the oxygen-conducting electrolyte is preferable due to the lesser tendency for carbon formation over the anode.

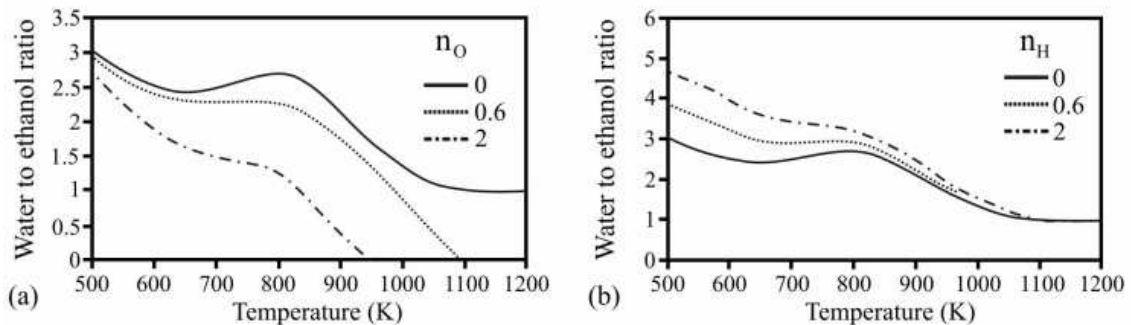

Figure 4- Boundary of carbonization in function of: (a) number of moles of oxygen that enters into the system, n_O , for a SOFC-O₂⁻; (b) number of moles of hydrogen that leaves the system, n_H , for a SOFC-H⁺.

Carbon activities were determined with the help of Eq. (5). Figure 5 (a) shows the influence of operating temperatures and of the type of electrolyte on the carbon activity considering three different situations: (a) ethanol steam reforming in a reformer; (b) the electrochemical reaction is occurring in a SOFC-O₂⁻, in which there are 2 moles of additional oxygen entering into the system; (c) the electrochemical reaction is occurring in a SOFC-H⁺, in which there are 2 moles of H₂ leaving the system. In all situations, the water to ethanol ratio in feed was equal to 2:1. This ratio was chosen just for sake of illustration.

Other ratios could be considered in these computations. According to Tsiakaras and Demin (2001), a steam to ethanol inlet ratio in the range of 1-5 is suitable from a practical point of view. As can be seen in Fig. 5 (a), the greater values for carbon activity were obtained for the case of hydrogen-conducting electrolyte, while the smaller ones were obtained when the SOFC with oxygen-conducting electrolyte was considered. Assabumrungrat et al. (2004) also verified the lesser tendency for carbon formation over the anode in a SOFC-O₂-. Figure 5 (b) shows the values of Lagrange multipliers of carbon component divided by RT used in Eq. (5) to calculate carbon activities shown in Fig 5 (a).

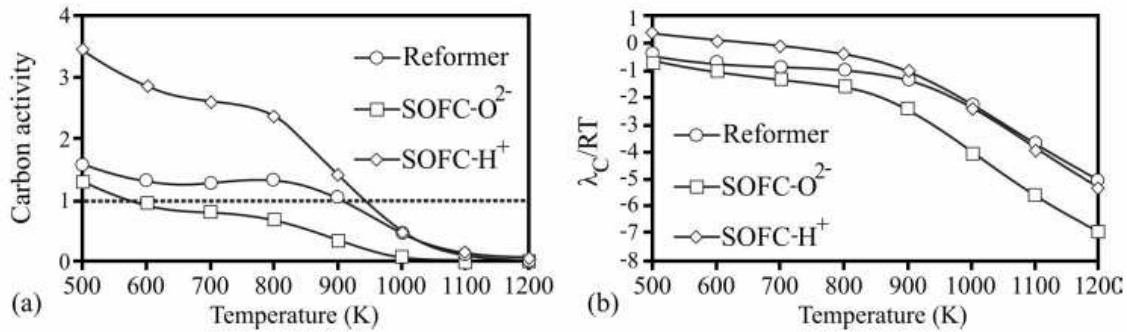

Figure 5- (a) Carbon activity in function of temperature.

H₂O/ethanol = 2:1. Influence of type of electrolyte (oxygen or hydrogen-conducting) on carbon activity; (b) Lagrange multipliers (divided by RT) in function of temperature. 3.3 SOFC-O₂- theoretical efficiency determination Theoretical analysis of the SOFC-O₂- efficiency is performed in high temperatures, of operational interest, in the range between 800 and 1200 K. It was assumed that an inlet gas into the SOFC-O₂- channel is an equilibrium mixture at boundary of carbonization. Figure 6 (a) illustrates the effect of temperature on the boundary of carbonization. Figure 6 (b) shows the thermodynamic equilibrium composition along the boundary of carbonization.

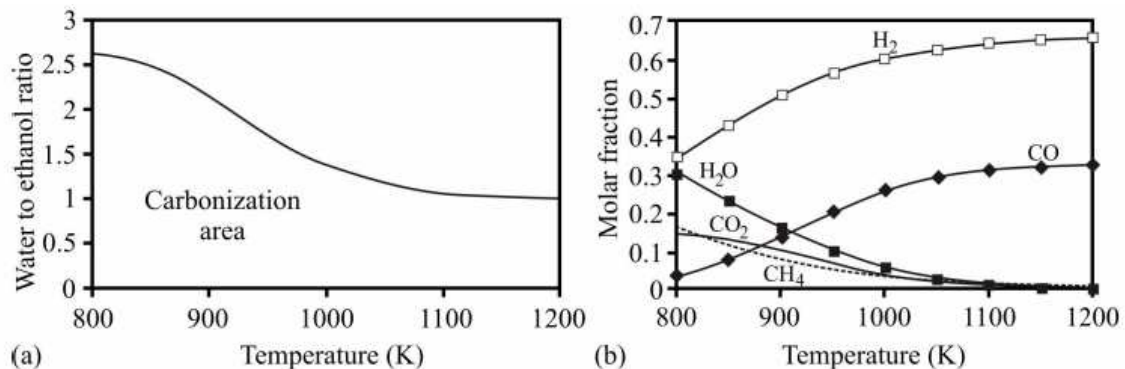

Figure 6- (a) Influence of temperature on boundary of carbonization; (b) Thermodynamic equilibrium composition at the boundary of carbonization

Figure 7 illustrates the electromotive force (E) distribution along the SOFC-O₂- channel dimensionless length (x/L). It can also be seen in Fig. 7 the additional number of moles of oxygen (nO) in the system, used in Eq. (3). It is possible to see that each value of length, x/L, corresponds to a respective value of additional number of moles of oxygen (nO), i.e., the species are gradually oxidized by the oxygen supplied through the electrolyte. The range of electromotive force (E) along the anode becomes wider as temperature increases. At low temperatures, E varies strongly only very close to the channel outlet, whereas at high temperatures E varies very strongly both at the inlet and at the outlet. Within the wide middle part of the channel, E varies only slightly at all temperatures examined. The electromotive force distribution calculated, in the present work, is in excellent agreement with the distribution presented by Tsiakaras and Demin (2001).

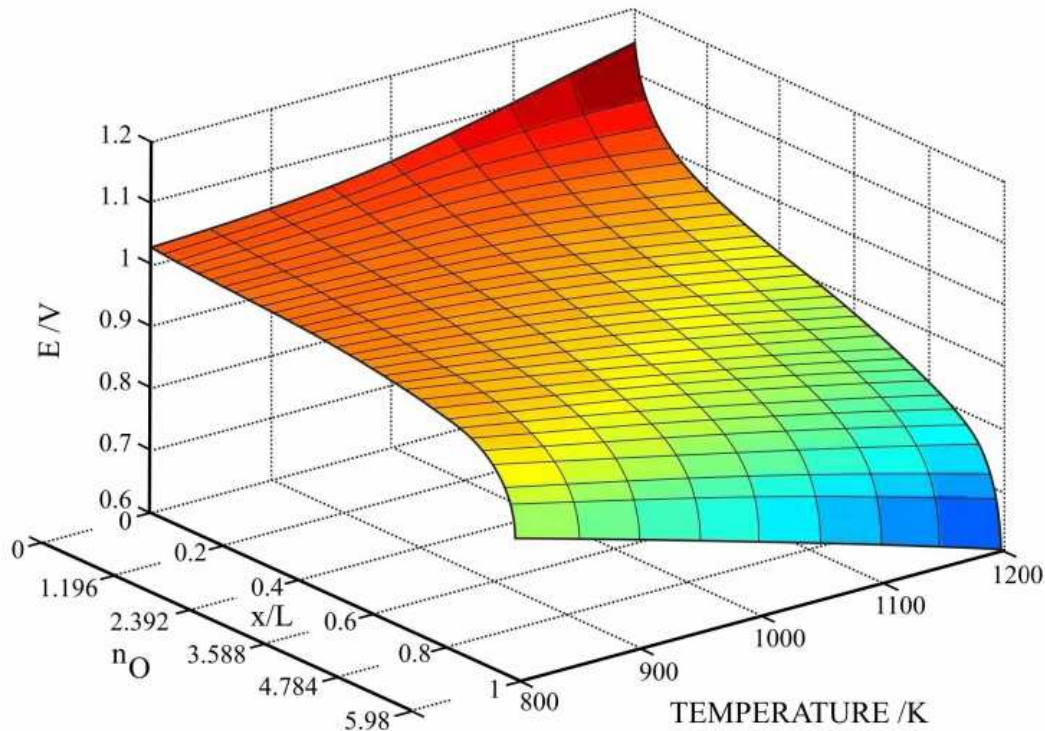

Figure 7- Effect of temperature on the distribution of electromotive force, E , along the SOFC dimensionless length, x/L . The inlet mixture corresponds to the boundary of carbonization. For each temperature, the maximum thermodynamic efficiency was calculated by means of numerical integration of electromotive force distribution along the SOFC dimensionless length, x/L . Figure 8 shows the temperature dependence of the maximum efficiency of the ethanol fueled SOFC-O₂. It can be seen that the efficiency, at the boundary of carbonization, is very high in the entire temperature region and increases as the temperature decreases. The theoretical efficiency obtained in this work varies between 84.1 and 93.5%, what is in agreement with the values of 83.9 and 93.8% presented by Tsiakaras and Demin (2001).

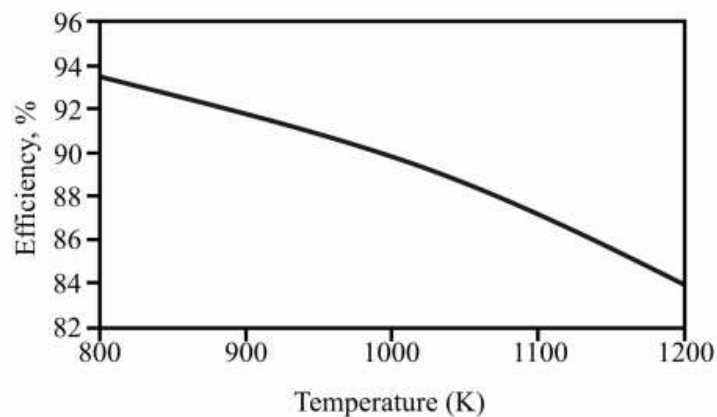

Figure 8- Temperature dependence of the maximum thermodynamic efficiency of the ethanol fueled SOFC-O₂.

Figure 8- Temperature dependence of the maximum thermodynamic efficiency of the ethanol fueled SOFC-O₂.

In practice, it is necessary to use gas compositions above the boundary of carbonization, i.e. systems with a H₂O:ethanol ratio higher than that shown in Fig. 6 (a).

As can be observed in Fig. 9, the SOFC-O₂- system efficiency increases with decreasing both temperature and water to ethanol ratio used in the reforming. Influence of the temperature decreasing on the maximum efficiency is more essential than influence of the ratio H₂O/ethanol decreasing.

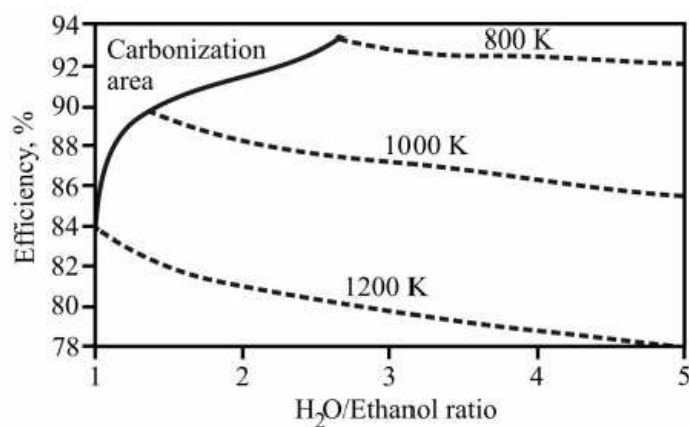

Figure 9- Dependence of the maximum thermodynamic efficiency of the ethanol fueled SOFC-O₂- on the H₂O/ethanol.

4 CONCLUSIONS

In this work, a thermodynamic analysis in order to predict the boundary of carbon formation for a SOFC with direct internal steam reforming of ethanol was presented. A comparison between the hydrogen-conducting electrolyte and the oxygen-conducting electrolyte shows that carbon formation is less favorable, at the same operating conditions, in a SOFC with the oxygen-conducting electrolyte. This is directly related to water produced from the electrochemical reaction of hydrogen at the electrodes. This can also be seen from the carbon activities values. At the same H₂O/ethanol ratio in feed and at the same temperature, the values of carbon activities are smaller for the oxygen-conducting electrolyte, while for hydrogen-conducting the values are greater.

The approach proposed in this work, to perform a thermodynamic analysis in a SOFC with direct internal reforming, considering either additional oxygen in system, for a SOFC-O₂-, or hydrogen moles that leave the system, for a SOFC-H₂+, in the constraints of elemental mass balance, is more realistic. This can be seen especially in case of SOFC-O₂-, because this model permits all species to react electrochemically with oxygen, not only H₂, as presented by other authors that employed the stoichiometric method. The values of the electromotive force as well as the calculated theoretical efficiencies, for a SOFC-O₂-, are in excellent agreement with previous values reported in literature.

Acknowledgements

The authors are gratefully acknowledging CNPq and CAPES that provided funds for this research.

REFERENCES

- Assabumrungrat, S., Pavarajarn, V., Charojrochkul, S. & Laosiripojana, N., 2004. Thermodynamic analysis for a solid fuel cell with direct internal reforming fueled by ethanol. *Chemical Engineering Science*, vol. 59, n. 24, pp. 6015-6020. Elsevier.
- Clarke, S. H., Dicks, A. L., Pointon, K., Smith, T. A. & Swann, A., 1997. Catalytic aspects of the steam reforming of hydrocarbons in internal reforming fuel cells. *Catalysis Today*, vol. 38, n.4, pp.411-423. Elsevier.
- Demin, A. & Tsiakaras, P., 2001. Thermodynamic analysis of a hydrogen fed solid oxide fuel cell based on a proton conductor. *International Journal of Hydrogen Energy*, vol. 26, n. 10, pp. 1103-1108. Elsevier.
- Fuel Cell Handbook, 2002. Fuel Cell Performance. In EG&G Technical Services, Inc., pp.7-1, DOE/NETL-2002/1179.

- Jamsak, W., Assabumrungrat, S., Douglas, P.L., Laosiripojana, N. & Charojrochkul, S., 2006. Theoretical performance analysis of ethanol-fuelled solid oxide fuel cells with different electrolytes. *Chemical Engineering Journal*, vol. 119, n. 1, pp.11-18. Elsevier.
- Knacke, O., Kubaschewski, O. & Hesselmann, K., 1991. *Thermochemical Properties of Inorganic Substances*, pp. 264-811. Springer-Verlag.
- Maggio, G., Freni, S. & Cavallaro, J. 1998. Light alcohols/methane fuelled molten carbonate fuel cells: a comparative study. *Journal of Power Sources*, vol. 74, n.1, pp. 17-23. Elsevier.
- Mas, V., Kipreos, R., Amadeo, N. & Laborde, M., 2006. Thermodynamic analysis of ethanol/water system with the stoichiometric method. *International Journal of Hydrogen Energy*, vol. 31, n. 1, pp.21-28. Elsevier.
- Sandler, S., 1999. *Chemical and Engineering Thermodynamics*, pp. 745-747. John Wiley & Sons.
- Silva, A.L., Melo, C.G., Halmenschlager, C.M., Malfatti, C.F. & Heck, N.C., 2008. Simulação termodinâmica para células a combustível do tipo SOFC com reforma interna direta do etanol, www.ifi.unicamp.br/ceneh/WICaC2008/WICaC2008_PDF.htm, viewed on October 14, 2008, at 16:40 UT.
- Shimada, T., Wen, C., Taniguchi, N., Otomo, J. & Takahashi, H., 2004. The high temperature proton conductor BaZr_{0.4}Ce_{0.4}In_{0.2}O_{3-α}. *Journal of Power Sources*, vol. 131, n.1-2 ,pp 289-292. Elsevier.
- Tsiakaras, P. & Demin, A., 2001. Thermodynamic analysis of a solid oxide fuel cell system fuelled by ethanol. *Journal of Power Sources*, vol. 102, n. 1-2, pp. 210-217. Elsevier.